

ISDN Terminal Adapter User's Guide

Rev. 3.0
JUL 1,2003

TABLE OF CONTENTS

INTRODUCTION	1
Features	1
INSTALLATION	2
Packing List	2
Connecting the Cables	2
LED Indicators	3
Verification	3
CONFIGURATION	5
Configuring by Utility	5
Configuring by AT Command	6
Configuring by Tone Command	7
PHONE NUMBER ASSIGNMENT	8
ANALOG DEVICE SUPPORT	10
Placing Calls	10
Receiving Calls	10
Intercom	11
Supplementary Service	11
Supplementary Service Controlling TYPE I	11
Call Hold	12
Call Waiting	12
Call Transfer Between Analog Ports	12
Call Transfer Through ISDN	12
Three-Party Conference(*)	13
Supplementary Service I Command List	13
Supplementary Service Controlling TYPE II	13
Call Hold	14
Call Waiting	14
Call Transfer Between Analog Ports	14

Call Transfer Through ISDN _____	15
Three-Party Conference _____	15
Supplementary Service II Command List _____	15
<i>ACCESSING THE INTERNET</i> _____	16
Installing the Windows Driver (INF file) for RS-232 Data Port _____	16
Installing the Windows 2000/XP Driver for USB Data Port _____	20
Installing the Windows 98/98SE/ME Driver for USB Data Port _____	21
Configuring Windows XP Dial-Up Networking ____	25
Install the New Dial-Up Connection _____	25
Dial the new Connection _____	27
Set up Data Connection Bandwidth (64K/128K) by Utility ____	28
Configuring Windows 98 Dial-Up Networking ____	29
Install the New Dial-Up Connection _____	29
Advanced Data Connection Settings _____	32
PPP Options _____	34
Authentication Conversion _____	34
Call Bumping - Bandwidth Release for Voice Call _____	34
Bandwidth On Demand (BOD) _____	34
<i>ADVANCED FEATURES</i> _____	36
Sub Address _____	36
Incoming Call Screening _____	36
Outgoing Call Screening _____	37
Caller ID _____	37
Type 1: On-Hook Caller ID Transmission _____	37
Type 2: Off-Hook Caller ID Transmission _____	38
<i>FIRMWARE UPGRADE</i> _____	39
<i>TROUBLESHOOTING</i> _____	40
<i>TONE AND RING PATTERNS</i> _____	41
<i>AT COMMAND LIST</i> _____	42

<i>TONE COMMAND LIST</i>	<i>47</i>
<i>TERMINATION RESISTOR</i>	<i>48</i>
<i>SPECIFICATIONS</i>	<i>49</i>

1

INTRODUCTION

This chapter describes the features of your ISDN terminal adapter--referred to from this point forward as TA.

Features

- ◆ Supports one RS-232 data port. The data rate is up to 230.4 Kbps.
- ◆ Supports one USB data port. USB spec 1.1 (12Mbps).
- ◆ Supports two analog ports for traditional devices, such as a telephone, modem, or G3 fax.
- ◆ Supports Async-to-Sync PPP or Multi-link PPP to allow you to access the Internet.
- ◆ Supports bandwidth release for voice calls. You need not miss any incoming voice call while you are accessing the Internet at 128 Kbps. Similarly, the system will release one channel if you pick up the phone to make a dial out call.
- ◆ Bandwidth-On-Demand adds or drops the second channel depending on the data traffic.
- ◆ Supports V.120 on B channel and X.25 on D channel data protocols to extend your data communication.
- ◆ Incoming call screening allows you to reject unwanted calls or to monitor important calls.
- ◆ Outgoing call screening lets you restrict access to outside numbers.
- ◆ Supports supplementary services for voice calls, including call hold, call waiting, call transfer, and three-party conference calls.
- ◆ Equipped with flash memory for easy local or remote firmware upgrades.
- ◆ Comprehensive diagnostic self-test function.

INSTALLATION

This chapter describes the installation procedure for your TA.

Packing List

Your package should come with the equipment listed below. If any item is missing or damaged, notify your dealer immediately.

- ◆ One ISDN terminal adapter.
- ◆ One external AC power cord.
- ◆ One RJ-11 cable.
- ◆ One serial DTE cable (RS-232C)
- ◆ One USB cable.
- ◆ One 3.5" installation disk or One CD-ROM.
- ◆ One User's Guide or Refer to Manuals in CD-ROM.

Connecting the Cables

Follow the steps below to connect the cables to your TA (see Figure 1):

1. Make sure your TA is turned off before you connect the cables. The power switch is located on the right side panel.
2. Connect the RJ-11 end of the ISDN cable to the jack labeled U on the rear of the device and connect the other end of the ISDN cable to your ISDN wall jack. If you have more than one ISDN device and want them to be connected in a series via S/T, you may have to change the ISDN line termination. See "Appendix D Termination Resistor" for more information.
3. (This step is optional) Connect cables from analog devices (telephones, fax machines, modem, etc.) to the jacks labeled TEL1 and TEL2 on the rear of the device.
4. Connect one end of the serial cable (RS-232C) to the port labeled DATA1 (RS-232) on the rear of the TA, and the other end to the appropriate serial port (as COM1 or COM2) on your computer.
5. (Refer Chapter 6 before connecting USB cable) Connect one end of the USB cable to the port labeled DATA2 (USB) on the rear of the TA, and the other end to the USB connector on your computer (if your computer supports USB interface).
6. Connect the external AC power cord connector to the power jack on the rear of the device. Then plug into an AC power outlet.
7. Turn on the power switch, and wait about 3 seconds for the TA to initialize. Now your device is operational based on the previous configuration.

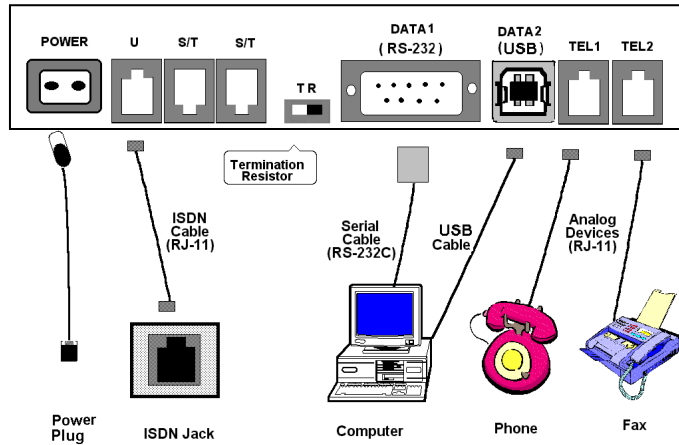

Figure 1 Rear panel of ISDN terminal adapter

LED Indicators

Your TA has eight LED indicators on the front panel.



Figure 2 Front panel of ISDN terminal adapter

1. PWR: The power on LED lights up when the device's local power supply is turned on.
2. LINE: The **green** line LED lights up when the line with the local switch is active. Else **yellow** line LED lights up.
3. TEL1: The TEL1 LED lights up when the telephone/handset connected to TEL1 is active, and flashes when an outgoing call is being placed or an incoming call is ringing.
4. TEL2: The TEL2 LED lights up when the telephone/handset connected to TEL2 is active, and flashes when an outgoing call is being placed or an incoming call is ringing.
5. DATA: The data LED lights up when the data call exists, and flashes when attempting to make a connection.
6. 128K: The 128K LED flashes when attempting to establish second channel if Multi-link PPP is active, and lights up when the second channel also active.
7. DTR: The **D**ata **T**erminal **R**eady LED lights up for serial DATA1 port when the computer (DTE) connected to the TA indicates that it is ready for communication by raising the corresponding RS-232 signal.
8. USB: This LED lights up for DATA2 port when the TA is ready for communicating with a computer through the USB interface.

Verification

After you have finished the installation, you should make a voice call to yourself

from TEL1 to TEL2 through the ISDN line to verify the installation is complete.

If you already have an ISP account, you can also make a data call to your ISP and connect to the Internet (see Chapter Six, "Accessing the Internet").

3

CONFIGURATION

This chapter describes the configuration procedure for your TA.

Configuring by Utility

The configuration utility is a graphical user interface tool runs on MS-Windows® platform that helps you to configure TA.

Follow these steps:

1. Make sure the serial RS-232 data port installation described in chapter 2 has completed, the way to use Utility via USB data port is similar after your USB driver has been installed (see Chapter 6 for the installation of USB driver).
2. Execute the Utility (file named "ConfigNTAxxx.exe" in the "Utility\" directory),

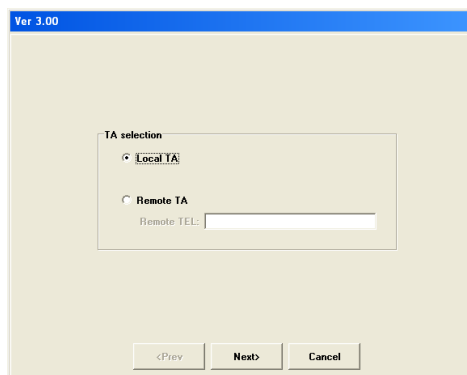

3. Click "Next" to access TA through the connected data port.

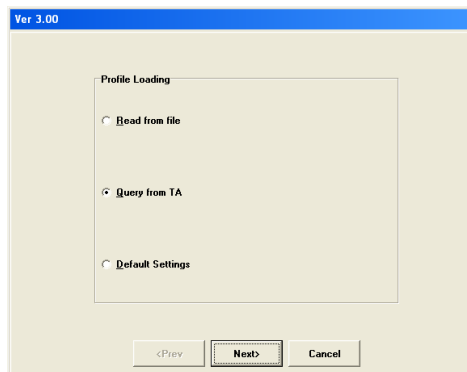

4. Click "Next" to query current setting from TA.

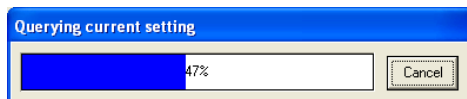

5. Here shows the Utility main window,

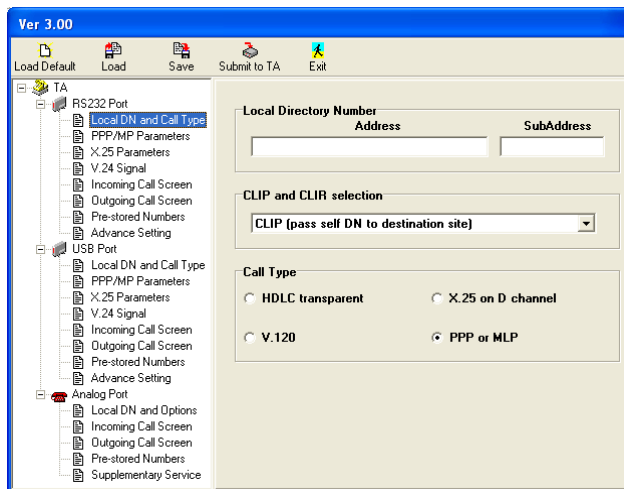

6. RS232 port, USB port and Analog port are the main interfaces to be configured, choose related item in the left window and change the corresponding value in the right. For the main menu,

- ◆ Load Default: Load factory default setting into Utility.
- ◆ Load: Load the Utility setting form a previous saved file.
- ◆ Save: Save current Utility setting to a file.
- ◆ Submit to TA: Send the Utility setting into TA. Utility will not modify any TA internal setting until you click “Submit to TA” function.
- ◆ Exit: Exit and close the Utility

Configuring by AT Command

AT commands are used to configure and control the device. An AT command line is needed to execute this input. Each command line begins with the letters “AT” or “at”, followed by one or more commands, and ends with <Enter>. To use AT commands to configure your TA, you will need a terminal program, e.g. Hyper-Terminal of Windows®.

Follow these steps:

1. Make sure the serial RS-232 data port installation described in chapter 2 has completed, the way to use AT commands via USB data port is similar after your USB driver has been installed (see Chapter 6 for the installation of USB driver).
2. Activate the terminal program. You must set the baud rate between 9600 and 230400 bps, and select a COM port.
3. Check to see if the DTR LED is on. If not, please check the settings of the terminal program as well as the cable between the connectors.
4. Type “AT”<Enter> from your terminal program. The device should respond “OK”. Once you receive that response, the TA is ready to be programmed. You can use the AT commands listed in Appendix B to configure it.

Configuring by Tone Command

Your TA facilitates use of a tone command to program the analog ports with a telephone set. It is very convenient for users when no PC or data terminals are available.

The procedure for using tone commands is as follows:

1. Pick up the phone attached to the analog port that you want to program.
2. Input the tone command key “***”. You will hear a configuration tone (CFG T, see Appendix A).
3. Input the tone command (listed in Appendix C). A configuration confirmation tone (CFMT) sounds if the tone command is valid. You can continue to input the next command without needing to use the tone command key again.
4. If the command is invalid, the device rejects it and generates a busy tone (BT). Please hang up the phone and repeat the procedure from step 1 if you want to try to input the tone command again.

4

PHONE NUMBER ASSIGNMENT

This chapter describes the procedure for applying for more than one phone number.

Having an ISDN connection, it is possible for you to apply to your provider (telephone company) for more than one phone number. This service is referred as Multiple Subscriber Numbers (MSN). With MSN service, you can assign different numbers for different ports or applications. The device provides five entry options for phone number assignment, including:

- ◆ Phone number for TEL1 port
- ◆ Phone number for TEL2 port
- ◆ Phone number for DATA1 port (RS-232)
With ISDN service, any incoming call will contain extra-information to tell whether it is a data or a voice call. Therefore, you can assign the data port the same phone number with one of the analog ports.
- ◆ Phone number for DATA2 port (USB)
- ◆ Phone number for X.25
The device supports X.25 functions. Normally, a phone number for X.25 is different from that for a voice call. Before using this feature, please contact your telephone company to get an X.25 number and assign it to this field.

The following example will help you to understand the assignment of phone number. Assume you receive two phone numbers (5009001, 5009002) from your ISDN provider, and attach one telephone on TEL1, one fax machine on TEL2. If you don't assign any phone number to either analog port, the incoming call will ring both telephone set (on TEL1) and fax machine (on TEL2). It's difficult to tell if it is a voice call or a fax call.

You need to:

Assign "5009001" for TEL1:

use AT Command: **AT!1S=5009001<Enter>**

OR

use Tone Command: *****310*5009001#**

Assign "5009002" for TEL2:

use AT Command: **AT!2S=5009002<Enter>**

OR

use Tone Command: *****310*5009002#**

You may apply the Utility to assign the Phone Number (Local Directory Number),

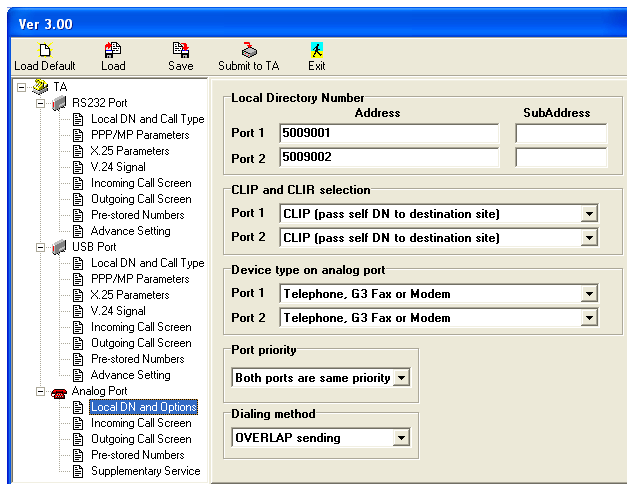

The device will pass an incoming voice call to TEL1 if the call is for “5009001” or pass the fax call to TEL2 if the number being called is “5009002.”

ANALOG DEVICE SUPPORT

This chapter describes support for the two analog device ports.

The device provides two analog device ports (TEL1, TEL2). These two ports let you connect analog devices such as ordinary telephones, answering machines, G3 fax machines, or modems to your TA. Calls to and from these analog devices are carried over an ISDN line, just like over a traditional telephone system. You also get additional features, such as intercom, call screening, supplementary service (including call hold, call waiting, call transfer, and three-party conference), etc.

Placing Calls

To make a call through the analog ports, dial the direct telephone number. Additionally, the device supports "Speed Dial." You can store up to five frequently used destination phone numbers, such as your family's phone number, into the TA. Then, you can place a call by dialing a limited number of digits.

For example:

1. To store destination phone number "5009001,"
use AT Command: **AT\Z0=5009001<Enter>**
or
use Tone Command: *****130*5009001#**
or
use Utility, setup number in "Analog Port/Pre-stored Numbers"
2. Then pick up the phone and dial "00#".

Receiving Calls

To 'answer' a call, just pick up the phone when it is ringing. Your TA assigns the incoming call to one or both analog device ports, depending on the phone number assignment. If both ports can accept the incoming call, e.g. the same phone number is used for both, then the device will check the priority of analog ports. If they have the same priority, it will send ring signals to both ports.

You can set the same priority for each of the two analog ports.

Do the following:

- use AT Command: **AT\P2=0<Enter>**
- or
- use Tone Command: *****122*0#**
- or
- use Utility, setup Port priority in "Analog Port/Local DN and Options"

You also can select TEL1 as high priority as follows:

- use AT Command: **AT\P2=1<Enter>**
- or
- use Tone Command: *****122*1#**

TEL1 MSN	TEL2 MSN	Priority	TEL1	TEL2
Unassigned Or Matched	Unassigned or Matched	0	Ring	Ring
Unassigned Or Matched	Unassigned or Matched	1	Ring	-
Unassigned Or Matched	Unassigned or Matched	2	-	Ring
Matched	Not matched	None	Ring	-
Not matched	Matched	None	-	Ring
Not matched	Not matched	None	-	-

Intercom

Intercom allows you to place calls between two analog devices on your TA without incurring any charge from the telephone company. No setup is required for this feature. You just pick up the phone and dial "1#".

Supplementary Service

With the device, you can access a variety of calling features known as supplementary service, including call hold, call waiting, call transfer, and three-party conference call.

There are two manipulated methods for supplementary service: the first one (**TYPE I**) is controlled mainly by 'Flash' key and for country like Some European countries/China. The second (**TYPE II**) is controlled by 'Flash' key combined with a Numbering key, for applying to Spain/Brazil/Costa Rica/Columbia.

Supplementary Service Controlling TYPE I

The general procedure to access these services is:

1. Press 'Flash.' Continue step 2 if you hear a "sub command tone" (see Appendix A for SCT).

Note: *'Flash' is a key on your telephone. If you can not find such a key, you can click (no more than one second) the hook on your telephone.*

2. Input a "sub command" before the "sub command timer" expires. The default value of the "sub command timer" is 2 seconds. You can decrease the "sub command timer" to speed up the operation. Feature marked (*) later in this chapter will need "sub command timer".

use AT Command: **ATp3=1<Enter>**

or

use Tone Command: *****123*1#**

or

use Utility, setup sub-command timer to 1 in "Analog Port/Supplementary Services"

Call Hold

Call hold lets you suspend a voice conversation with a partner, and place a call to a second person. You can then toggle back and forth between the first and second party.

With a voice call on-line, press 'Flash', then the person you are speaking with is placed on hold, and you get a dial tone. Now, you can dial the number of the second person you want to call. After the second person answers the call, you can toggle back and forth between the two parties by pressing 'Flash'.

If you hang up while a call is on hold, the phone will get a "remind ring". Note that when you place a party on hold, the connection remains active.

Call Waiting

When you are on the phone and receive an incoming call, call waiting alerts you with a "call waiting tone" (CWT). When you hear the CWT, you may take one of the following actions:

- ◆ **Reject the incoming call (*).** Press 'Flash', wait for the "sub command tone", and then press '#0'. This feature is only available when the "sub command timer" is enabled.
- ◆ **Disconnect the first call and accept the incoming call.** Hang up the phone, wait for the ring, and pick up the phone.
- ◆ **Place the first call on hold and answer the incoming call.** If the "sub command timer" is enabled, press 'Flash' and then wait for the "sub command tone". The action will be completed when the "sub command tone" ends. If the "sub command timer" is disabled, just press 'Flash' and then you can answer the incoming call immediately.

If the device on the analog port, e.g. TEL1, is a fax machine or a modem, CWT will disturb the data communication. We strongly recommend you disable this "call waiting" feature of any port to which you have connected either a fax machine or a modem. You can disable the "call waiting" feature as follows:

use AT Command: **AT!1A1=0<Enter>**

OR

use Tone Command: *****211*0#**

OR

use Utility, Disable call waiting in "Analog Port/Supplementary Services"

Call Transfer Between Analog Ports

If an **incoming call** is active on one device (e.g. a phone on TEL1), you can transfer the **incoming call** to another device (e.g. a phone on TEL2). Follow these steps:

1. Press 'Flash' to put the call on hold. You will get a dial tone.
2. Dial '1#' to make an intercom. The device on the other port will ring.
3. Hang up the phone.
4. The transfer is completed when the other device answers the transferred call.

Call Transfer Through ISDN

This feature requires call transfer to be supported by your telephone company. If an **incoming call** is active, you can transfer the **incoming call** to another party (not connected to the TA).

1. Press 'Flash' to put the call on hold. You will hear a dial tone.
2. You can dial the number of the person that you want to transfer.
3. Hang up the phone when you get the ring-back tone or if the destination device answers the call.

Three-Party Conference(*)

This feature requires three-party conference to be supported by your telephone company and the "sub command timer" must be enabled. This service allows you to establish a three-way conversation, i.e. a simultaneous communication between you and two other parties.

With a voice call on-line, press 'Flash'. The person you are speaking with is placed on hold, and you get a dial tone. Now, you can dial the number of the second person you want to call. After the second person answers the call, you can press 'Flash,' wait for the "sub command tone", and then press 'Flash' again to complete the three-party conference procedure. Hanging up the phone will terminate the conversation and disconnect both calls.

With three-party conference active, pressing 'Flash' will split the conversation into two individual calls. One is active, the other is on hold.

Supplementary Service I Command List

Some brief command summary for the above supplementary service:

- ◆ **'Flash'**: put current call on hold if there is only one on-line voice call.
- ◆ **'Flash'**: put current call on hold and answer the incoming call waiting call.
- ◆ **'Flash' + '#0'**: keep current call on line and reject the incoming call waiting call (*).
- ◆ **'Flash' + 'phone number'**: put current call on hold and to establish the second calling party; hang up the phone will transfer the call while the first call is an **incoming call**.
- ◆ **'Flash' + 'phone number', then 'Flash' + 'Flash'**: enter three-party conference (*).

'Flash': toggle back and forth between the first and second calling party. Or split the current three-party conference call into two individual calls.

Supplementary Service Controlling TYPE II

The general procedure to access these services is:

1. Press 'Flash'. Continue step 2 after you hear a "sub command tone" (see Appendix A for SCT).

Note: *'Flash' is a key on your telephone. If you can't find such a key, you can click (no more than one second) the hook on your telephone.*

2. Input a "sub command" before the "sub command timer" expires. The default value of the "sub command timer" is 2 seconds. If the timer expires without any "sub command" or an invalid "sub command" is entered, the current operation will be aborted.

Call Hold

Call hold lets you suspend a voice conversation with a partner, and place a call to a second person. You can then toggle back and forth between the first and second party.

With a voice call on-line, press 'Flash', then the person you are speaking with is placed on hold, and you get a dial tone. Now, you can dial the number of the second person you want to call.

After the second person answers the call, you can toggle back and forth between the two parties by pressing 'Flash' then '2'.

Press 'Flash' and then press '0', the on hold party will be disconnected and the current party will keep on-line.

Press 'Flash' and then press '1', the current party will be disconnected and the on hold party will be on-line.

If you hang up while a call is on hold, the phone will get a "remind ring". Note that when you place a party on hold, the connection remains active.

Call Waiting

When you are on the phone and receive an incoming call, call waiting alerts you with a "call waiting tone" (CWT). When you hear the CWT, you may take one of the following actions:

- ◆ **Reject the incoming call.** Press 'Flash', wait for the sub command tone, and then press '0'.
- ◆ **Disconnect the first call and accept the incoming call.** Press 'Flash', wait for the sub command tone, and then press '1'. Another straightforward way is to hang up the phone first, wait for the ring, and pick up the phone.
- ◆ **Place the first call on hold and answer the incoming call.** Press 'Flash' and then wait for the sub command tone, and press '2'. The action will be complete when the sub command tone ends and you can answer the incoming call immediately.

If the device on the analog port, e.g. TEL1, is a fax machine or a modem, CWT will disturb the data communication. We strongly recommend you disable this "call waiting" feature of any port to which you have connected either a fax machine or a modem. You can disable the "call waiting" feature as follows:

use AT Command: **AT!1A1=0<Enter>**

or

use Tone Command: *****211*0#**

or

use Utility, Disable call waiting in "Analog Port/Supplementary Services"

Call Transfer Between Analog Ports

If an incoming call is active on one device (e.g. a phone on TEL1), you can transfer the call to another device (e.g. a phone on TEL2). Follow these steps:

1. Press 'Flash' to put the call on hold. You will get a dial tone.
2. Dial '1#' to make an intercom. The device on the other port will ring.
3. Press 'Flash', then press '4' to complete the transfer when you get the ring-back tone or if the other device answers the transferred call.

4. Hang up the phone.

Call Transfer Through ISDN

This feature requires call transfer to be supported by your telephone company. If an incoming call is active, you can transfer the call to another party (not connected to the TA).

1. Press 'Flash' to put the call on hold. You will hear a dial tone.
2. You can dial the number of the person that you want to transfer.
3. Press 'Flash', then press '4' to complete the transfer when you get the ring-back tone or if the destination device answers the call.
4. Hang up the phone.

Three-Party Conference

This feature requires three-party conference to be supported by your telephone company. This service allows you to establish a three-way conversation, i.e. a simultaneous communication between you and two other parties.

With a voice call on-line, press 'Flash'. The person you are speaking with is placed on hold, and you get a dial tone. Now, you can dial the number of the second person you want to call. After the second person answers the call, you can press 'Flash,' wait for the sub command tone, and then press '3' to complete the three-party conference procedure. Hanging up the phone will terminate the conversation and disconnect both calls.

With three-party conference active, pressing 'Flash', wait for the sub command tone, and then press '2' to will split the current conversation into two individual calls. One is active, the other is on hold.

Supplementary Service II Command List

Some brief command summary for the above supplementary service:

- ◆ **'Flash'**: put current call on hold if there is only one voice call on-line.
- ◆ **'Flash' + '0'**: disconnect on hold call or incoming call waiting call, and keep the current call on-line.
- ◆ **'Flash' + '1'**: disconnect current on-line call, and answer on hold or call waiting call.
- ◆ **'Flash' + '2'**: put current call on hold, and answer on hold or call waiting call. Or split the current three-party conference call into two individual calls.
- ◆ **'Flash' + '3'**: enter three-party conference
- ◆ **'Flash' + '4'**: transfer the call

ACCESSING THE INTERNET

This chapter contains procedures for installing Windows® 95/98/NT4.0/2000/XP drivers, as well as for configuring dial-up networking for your TA. The RS-232 data port drivers should work on all Windows platforms. While the USB data port drivers support only Windows 98(First Edition), Windows 98SE(Second Edition), Windows 98ME, Windows 2000, and Windows XP.

We will first take the installation of RS232 and USB driver on Windows XP as an **generic** example, then we will describe the **different** USB driver installing method on Windows 98/98SE/98ME.

Note: To tell the version of your Windows 98 system, open the System Properties window of “My Computer” folder (as right click on “My Computer” icon). The pop-out window will show the version information.

Note: For Windows 2000/XP applications, the “**Digital Signature Not Found**” window may appear warning that the installation software is not a digitally signed version. A digital signature is not necessary; the software has been tested with Windows 2000/XP. Click **Yes** to allow the installation to continue.

Installing the Windows Driver (INF file) for RS-232 Data Port

If your computer (Windows 98/2000/XP) and TA support Plug & Play, be sure your device is powered on before starting your computer. And **specify the correct driver location** for your Windows platform. Please refer the following step 4 and step 5 for more details.

Otherwise, follow the steps below to complete the installation:

1. Open Control Panel, and click “Printer and Other Hardware”, then select “Phone and Modem Options”,

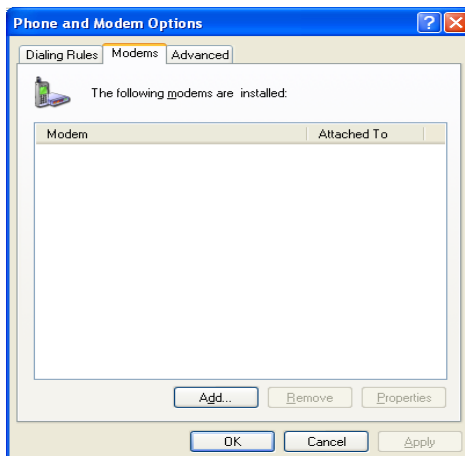

2. Click “Modems” and then click the “Add” button. The following dialog box will appear:



3. Select “Don’t detect my modem; I will select it from a list.” Then click “Next.” The following dialog box will appear:

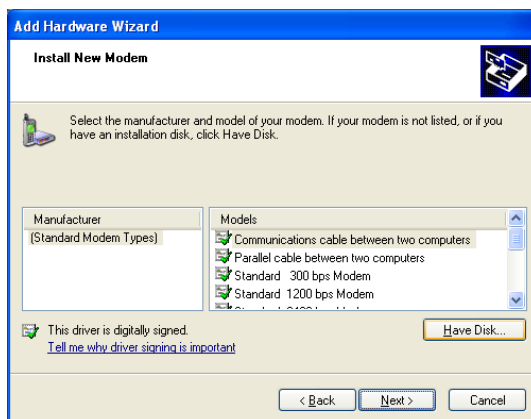

4. Insert TA driver disk or CD-ROM provided with your device into your **disk drive** or **CD-ROM drive**, and click the “Have Disk” button. Select the correct path of the driver (“*TA.inf*”).

For Windows 95/98/NT 4.0, the path is: \DRIVER\WIN98\.

For Windows 98SE or 98ME, the path is: \DRIVER\WIN98SE_ME\.

For Windows 2000, the path is: \DRIVER\WIN2000\.

For Windows XP, the path is: \DRIVER\WINXP\.

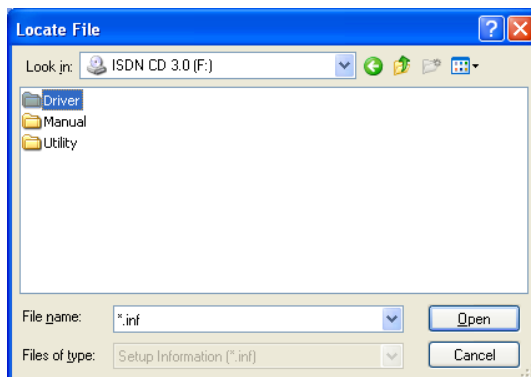

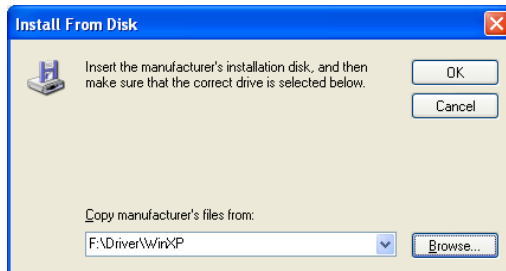
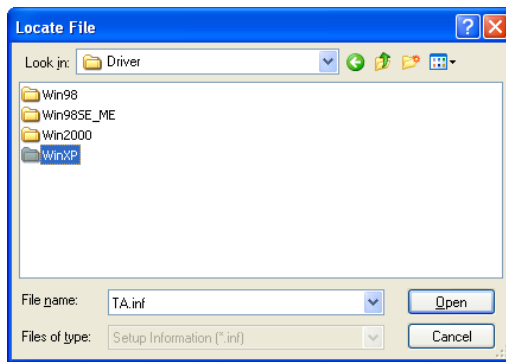

5. Then click “OK”. If you have downloaded an updated INF file from Web site, use “Browse” to find the location of the updated INF file, click “Open,” and then click “OK.”

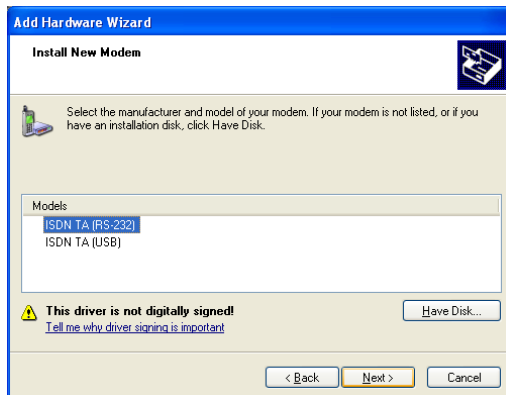

6. Select the model “RS-232” and click “Next”.

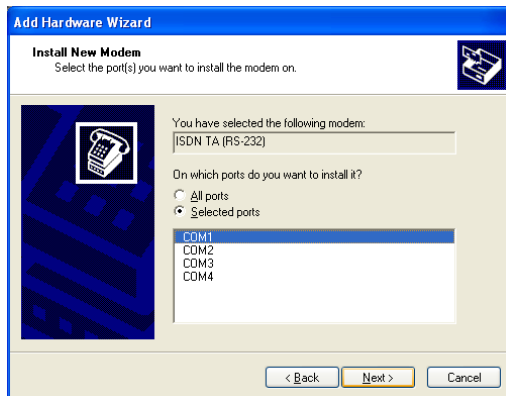

7. Select the COM port your TA is connected to and click “Next”.

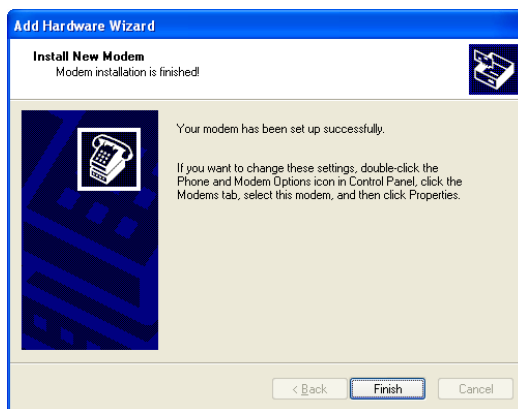

- Click “Continue Anyway” if you turn on the “Driver Signing” checking option. A finished dialog box will appear. Click “Finish.”

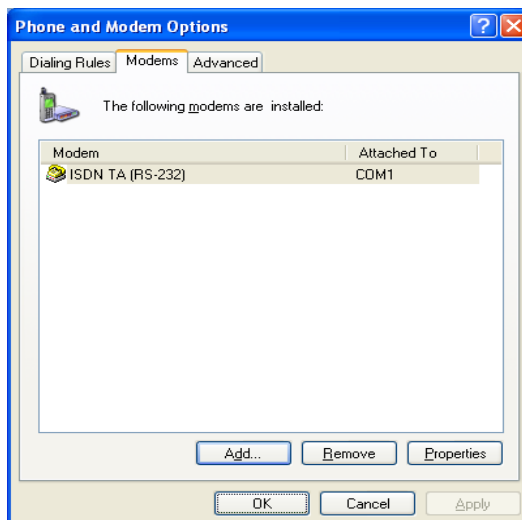

- The installed device should appear in the “Phone and Modem Options” Window. You may now use programs such as “Dial-Up Networking” with your TA via RS-232 port.

Installing the Windows 2000/XP Driver for USB Data Port

If your computer and TA support USB, be sure your device and your computer are both powered on. Then plug in the USB cable and the Plug and Play installation sequence will start.

NOTE: To use USB, you must have Windows 98, 2000, XP or Millennium installed on your PC. USB cannot run in a Windows 95 or NT environment. Also, your PC must have a USB port installed and enabled. If your USB port doesn't seem to be working, there may be jumpers on the motherboard or a menu option in the BIOS to enable a PC's USB port. The installation procedure for Windows 2000/XP USB port is similar to RS-232 data port.

1. In the Hardware Wizard,



2. Insert the TA driver disk or CD-ROM provided with your device. Click "Next", and guide Windows to locate the correct driver path ("*TA.inf*").

For Windows 2000, the path is: `\DRIVER\WIN2000\`.

For Windows XP, the path is: `\DRIVER\WINXP\`.

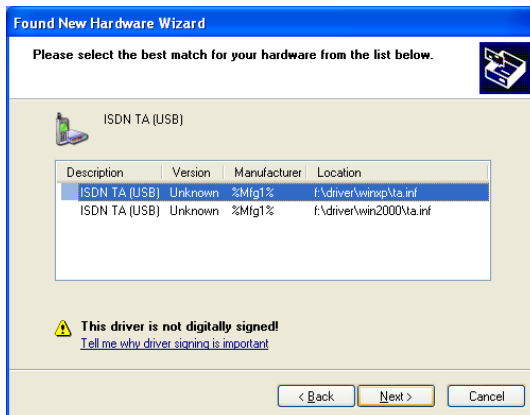

3. Click "Next", and select "Continue Anyway" if "Driver Signing" screen appear,

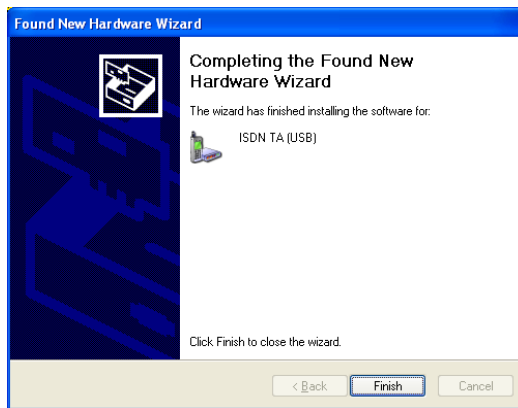

4. Click “Finish” to complete the installation.
5. If you open the “Phone and Modem Options” window, you should see the installed device like the following. (Control Panel→Printer and Other Hardware→Phone and Modem Options).

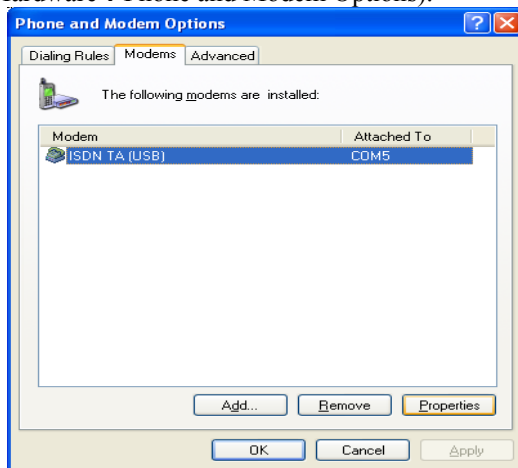

Installing the Windows 98/98SE/ME Driver for USB Data Port

If your computer and TA support USB, be sure your device and your computer are both powered on. Then plug in the USB cable and the Plug and Play installation sequence will start.

NOTE: *USB cannot run in a Windows 95 or NT environment. Also, your PC must have a USB port installed and enabled..*

1. In the Hardware Wizard,



2. Insert the TA driver disk or CD-ROM provided with your device, then click "Next".



3. Specific or Browse the correct driver location,
For Windows 98, the driver (INF) path is: `\DRIVER\WIN98\`.
For Windows 98SE or 98ME, the path is: `\DRIVER\WIN98SE_ME\`.



4. Select "USB TA" model as the first installation., click "Next".



NOTE: For Windows 98 series platform installation, you will install the USB driver (USBTAWDM.inf: WDM driver) layer first. Then it will activate the real TA driver (TA.inf) as the second installation.



5. Click "Finish" in the dialog box after "USB TA" drivers have been copied into your system. And this will invoke the second installation automatically. The following steps are similar to the RS-232 data port installation.





6. Click “Finish”. You may now use programs such as “Dial-Up Networking” with your TA via USB port.

NOTE: *You need to restart your computer to make the device work after installation.*

Configuring Windows XP Dial-Up Networking

This section assumes you have already fully installed Windows XP. If you have not installed the Dial-Up Networking feature in Windows XP, please install it before you continue.

Install the New Dial-Up Connection

1. Open “Control Panel”, click “Network and Internet Connections”, pick “Create a connection to the network...”.

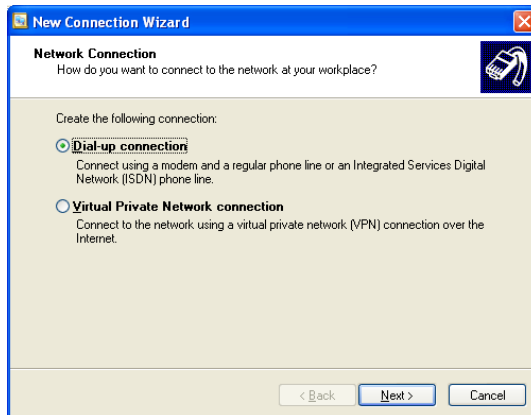

2. Click “Next”,

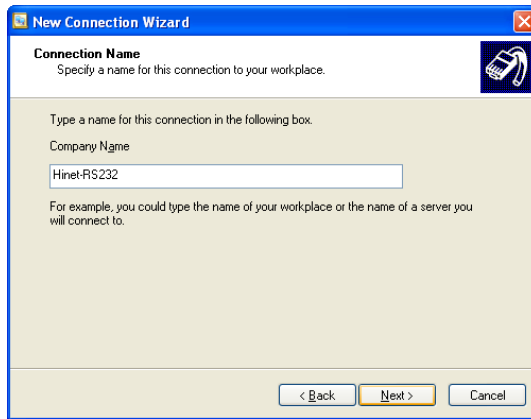

3. Type in your connection name,

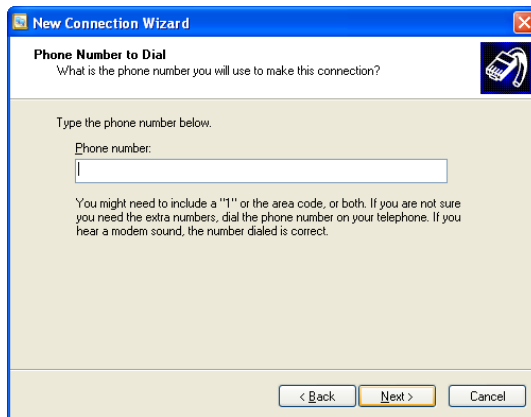

4. And the dialing number (ISP phone number),

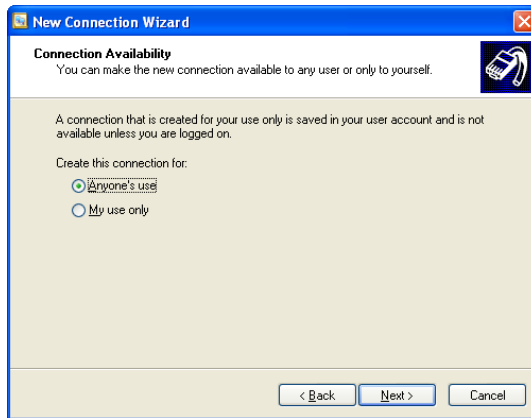



5. Click “Finish” to complete.

Dial the new Connection

1. Click to dial the new Connection, (in “Control Panel”→“Network and Internet Connection”→ “Network Connections” window)

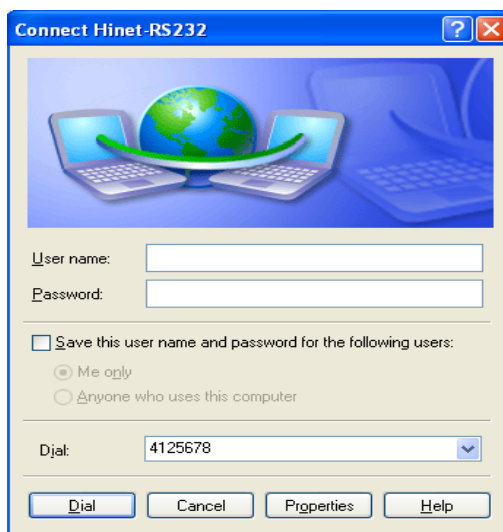

2. Type in the correct User name and Password,

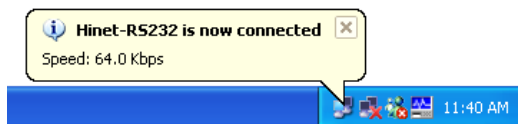

3. Here shows 64Kbps connection in Windows task tray.

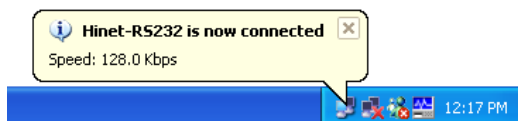

4. Here's 128Kbps (Fixed or Dynamic MLP)

Set up Data Connection Bandwidth (64K/128K) by Utility

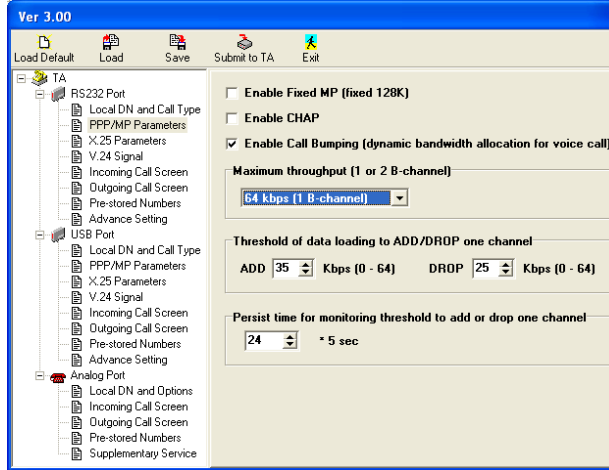

Maximum 64Kbps. (PPP)

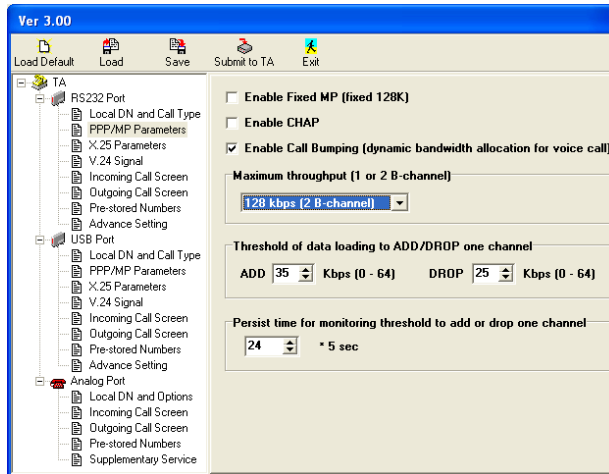

Dynamic 128Kbps. (Dynamic MLP)

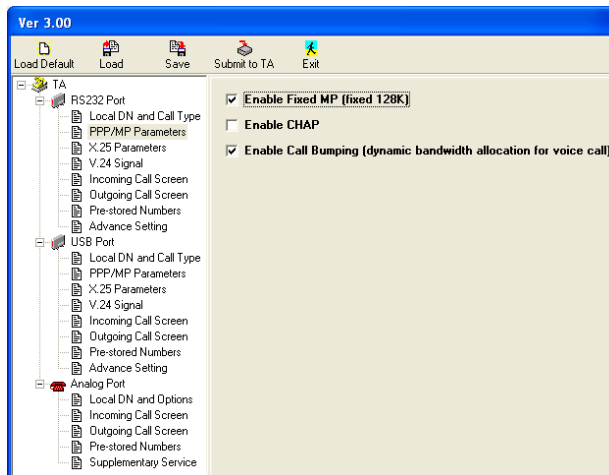

Fixed 128Kbps. (Fixed MLP)

Note: When you choose *Fixed* or *Dynamic 128K*, be sure to check “**Allow unsecured password**” in the Connection “*Properties*”. See the section entitled “**PPP Options**” later in this chapter for further details.

Configuring Windows 98 Dial-Up Networking

Here we take Windows 98 platform as a generic example, the procedures for Windows 95 and Windows 2000 are similar.

If you have not installed the Dial-Up Networking feature in Windows 98, please install it before you continue.

Install the New Dial-Up Connection

1. Double-click the “My Computer” icon and then double-click the “Dial-Up Networking” icon. From within the Dial-Up Networking folder, double-click the “Make New Connection” icon.

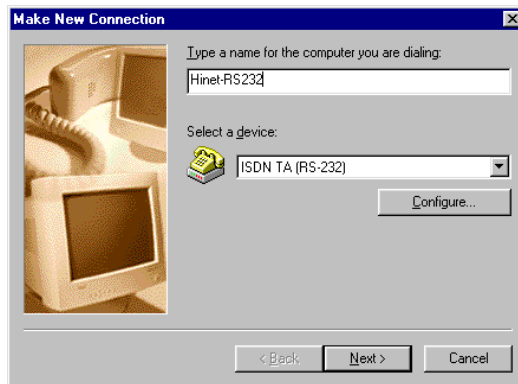

2. Choose a name for your connection and select your modem type from the drop down window. Then click the “Next” button.

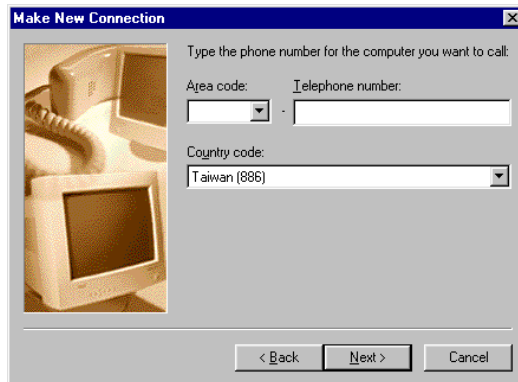

3. Select the country and type the phone number of your ISP. Click the “Next” button.



4. Click "Finish".

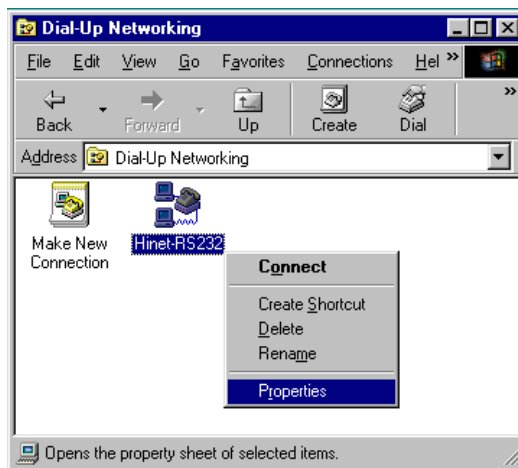

5. Configure the Properties of your new dial-up connection.

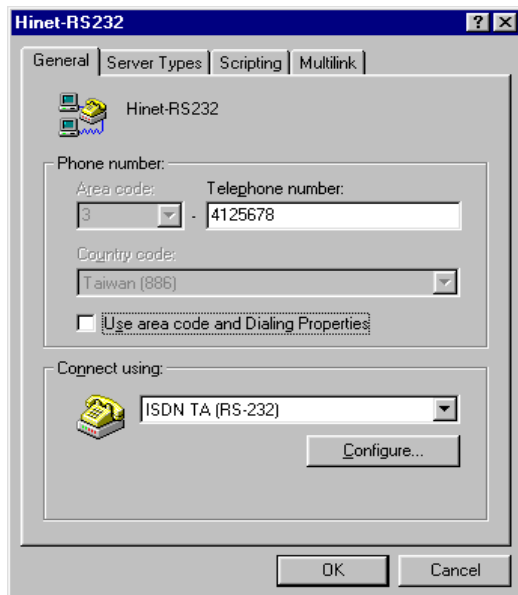

6. Un-check area code if you are dialing the local phone number in the "General" window.

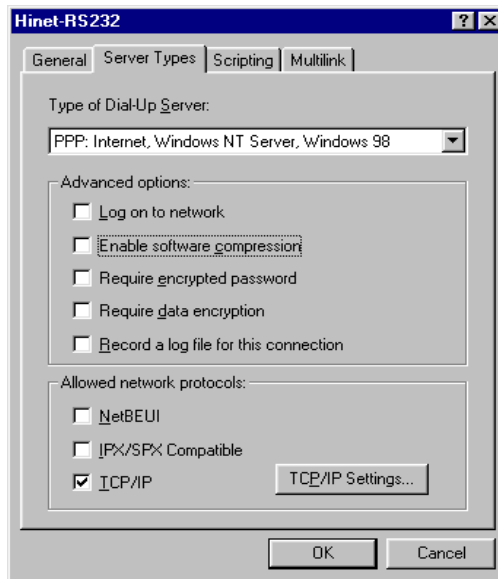

7. Click the “Server Types” tab, and use the default setting shown above.

Note: Be sure not to check “**Require encrypted password**” when you choose Fixed or Dynamic 128K. See the section entitled “**PPP Options**” later in this chapter for further details.

If your ISP supports Microsoft software compression, you can also check “Enable software compression”.

If you are connecting to a LAN, then select “Log on to network.”

If you are logging on to a Microsoft Windows network, select “NetBEUI.”

If you are logging on to a Novell network, then select “IPX/SPX Compatible.”

If you are logging on to an Internet connection, then select “TCP/IP.”

8. Click “TCP/IP Settings.”

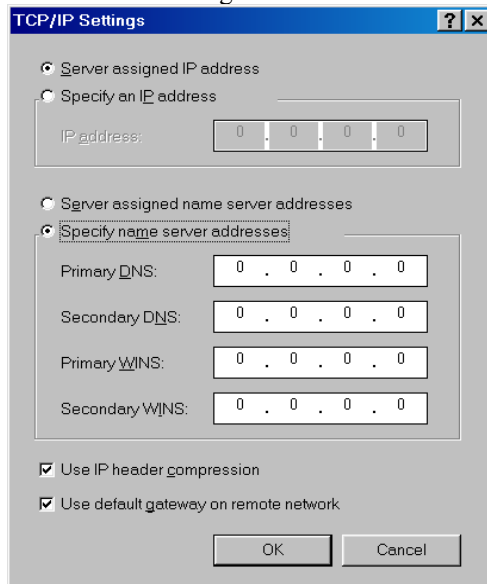

9. If your host requires you to specify an IP address (Static IP), then check “Specify an IP address” and enter your IP address. Otherwise, check “Server assigned IP address.” Most servers assign an IP to you when you log in.
10. Check “Specify name server addresses” and enter your primary and secondary DNS (Domain Name Server) IP. Obtain the DNS numbers from your ISP. In most cases, you should leave “Use IP header compression” and “Use default gateway on remote network” checked. When all of the selections have been made, click “OK”.
11. Locate the new connection icon in your “Dial-up Networking” folder, and double-click it.

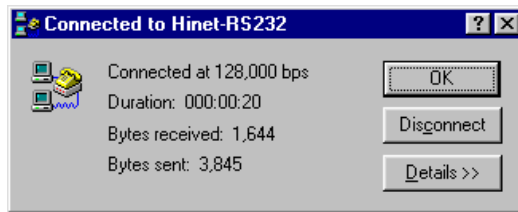

Advanced Data Connection Settings

You may execute the Utility to change the 64K/128K bandwidth setting. (Refer section “Set up Data Connection Bandwidth (64K/128K) by Utility” in Windows XP configuration)

This section describes the way to add some extra settings or to override some settings for your current connection.

1. Open “Properties” window of the connection (Right click on Connection icon).

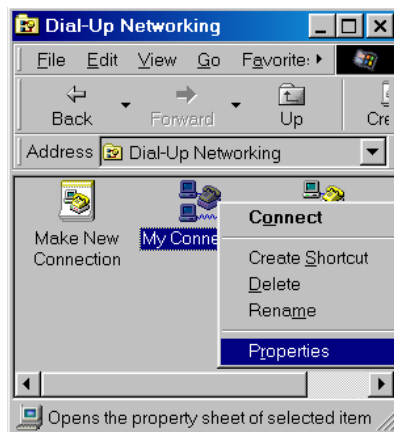

2. Click the “Configure” button to configure current connection.

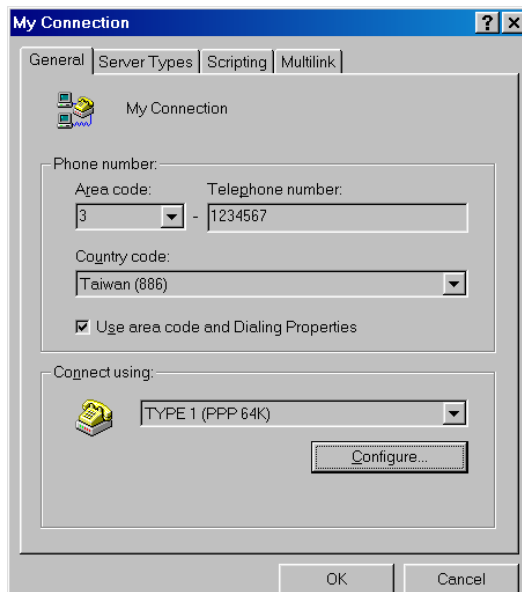

- Choose “Connection” item from the menu and press “Advanced” button in your next window, the following new window will appear:

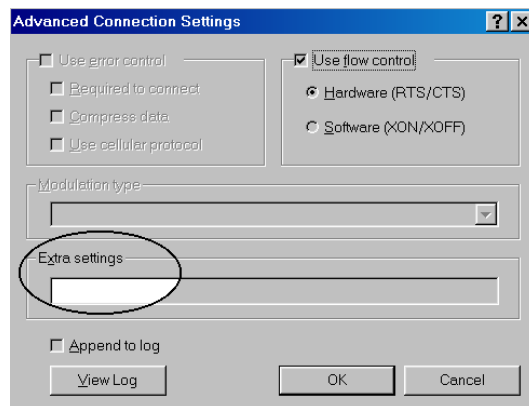

- You can type in some AT commands in the **Extra settings** filed for your current connection. For example, the following related commands override the default data call service type.

Commands for different data call type:

- ◆ ATC0=8C1=0: PPP (64K)
- ◆ ATC0=8C1=1: MLP (128K with **BOD**, please execute the configuration utility to adjust **BOD** parameters, refer section entitled “**BOD**” later in this chapter for more details)
- ◆ ATC0=4: V.120 (64K)

PPP Options

Authentication Conversion

After a connection is established, it is necessary to authenticate the peer for security reasons. Generally, the server will authenticate the client. There are two popular authentication methods. One is Password Authentication Protocol (PAP) and the other is Challenge Handshake Authentication Protocol (CHAP).

PAP is less secure because it transmits the username/password in plain text form. Unlike PAP, CHAP transmits the username/password in encrypted form. Your TA provides the username/password conversion from PAP to CHAP. Microsoft also provides username/password encryption if you check the "Required encrypted password" in the "Server Types" tab of the screen entitled "My Connection," but the method it uses is MS-CHAP and some ISPs don't support MS-CHAP. So we suggest that you don't enable MS-CHAP when connecting to ISP. **Be sure not to check the "Require encrypted password" in PC if you choose MLP 128K drivers** since your device needs the plain username/password from the PC to establish the connection. You can enable the authentication conversion **in TA** to encrypt your username/password when using MLP 128K drivers.

Related commands:

- ◆ AT%M1=0 Disable PAP -> CHAP conversion (default).
- ◆ AT%M1=1 Enable PAP -> CHAP conversion.

Note: *Before you enable this conversion, make sure that your ISP can accept CHAP username/password encryption and your PC sends the username/password in PAP format.*

Call Bumping - Bandwidth Release for Voice Call

You can place a voice call while Multi-link PPP is active and no channel is free. The device will drop one of the channels automatically and use it for a voice call. If a user has subscribed to call waiting service, the TA will also answer an incoming call by dropping one of the channels automatically. Once a voice call ends, the device may attempt to reestablish the data channel by the rule of BOD (see the next section for further information).

Related commands:

- ◆ AT%M2=0 Disable Bandwidth Release for Voice Call.
- ◆ AT%M2=1 Enable Bandwidth Release for Voice Call(default).

Bandwidth On Demand (BOD)

The function of bandwidth on demand (BOD) is to monitor the data traffic on ISDN links while using Multi-link PPP. If only one B channel is used and data traffic reaches or exceeds the high threshold value, BOD will establish a second B channel to increase the bandwidth of the data connection. On the other hand, if data traffic is light, i.e. below the low threshold value, one of the channels will be dropped automatically. **The BOD function only works on the client site. It will be disabled on the server site.** There are three parameters to control the BOD function. (see bellows)

Related commands:

- ◆ AT%M3=n, n=0~64 (Kbps): High threshold to add one channel, default n=0.

- ◆ AT%M4=n, n=0~64 (Kbps): Low threshold to drop one channel, default n=0.
- ◆ AT%M5=n, n=1~255 (time unit = 5 sec): The period for calculating traffic load, default n=1.
- ◆ Default case: AT%M2=1%M3=0%M4=0%M5=1 will disable BOD and will establish **fixed Multi-link PPP data call** with both B channels (i.e. fixed 128kbps bandwidth). And it will release bandwidth for voice call.

Note: *The high threshold must be greater than the low threshold, otherwise these two parameters will be reset to their default values.*

ADVANCED FEATURES

This chapter describes some of the advanced features offered by your TA.

Sub Address

In addition to MSN, ISDN service also provides sub-addresses, like extension numbers. You can assign a sub-address for each analog port or each data port during phone number assignment or make an outgoing call with a sub-address.

If you assign a sub-address as part of the phone number, the device will handle incoming calls, according to both the phone number and the sub-address, not only the phone number.

If you want to make an outgoing call through an analog port with sub-address,

1. You must select "en-bloc sending."
use AT Command: **AT\P1=1<Enter>**
or
use Tone Command: *****121*1#**
2. Pick up the phone, wait for a dial tone, input the destination phone number, press '*', and then input the sub-address and '#'.

Incoming Call Screening

Sometimes a person is waiting for one or maybe more than one very important incoming call and they hope no other call occupies the line. Now you can enable "Incoming Call Screening" to reject all incoming calls except the important calls that you select. In the same way, this feature can help you to reject one or more calls that you choose not to receive.

For example, if you want to enable this feature on TEL1,

1. Set "Incoming Call Screening Mode" to enable this feature. You can program the TA "only to accept some calls" by the following method:
use AT Command: **AT!1P0=2<Enter>**
or
use Tone Command: *****220*2#**

Or you can program the TA "only to reject some calls" by the following method:

- use AT Command: **AT!1P0=3<Enter>**
or
use Tone Command: *****220*3#**
2. Store the phone number(s), e.g. "5009001", of persons that you want to accept or reject--up to 5 can be entered. Follow these steps:
use AT Command: **AT!1I0=5009001<Enter>**

or

use Tone Command: *****320*5009001#**

To disable this feature, set “Incoming Call Screening Mode” to “accept all calls.”

Outgoing Call Screening

Sometimes you do not want to allow anybody to make a long-distance or international call through your TA. Enable “Outgoing Call Screening” to add such restrictions.

For example, if the prefix digits of an international call are “00”, you can set the restriction on TEL1 as follows,

1. Set “Outgoing Call Screening Mode” to “Reject Call by List.”

use AT Command: **AT!1P1=3<Enter>**

or

use Tone Command: *****221*3#**

2. Store the prefix digits of an international call into your list via a configure tool

or

use AT Command: **AT!1O0=00<Enter>**

or

use Tone Command: *****350*00#**

3. To disable this feature, set “Outgoing Call Screening Mode” to “accept all calls.”

Caller ID

The analog ports of TA will deliver Caller ID information for incoming phone call. The Caller ID device attached on analog port will display the calling telephone number. Two main Caller ID service types are supported by your TA.

Type 1: On-Hook Caller ID Transmission

Your Caller ID device will display the phone number before you decide to answer the incoming call. The analog line Caller ID protocol is accomplished by using Dual Tone Multi-Frequency (DTMF) signaling or Frequency-Shift Keying (FSK) signaling.

The configuration of TYPE 1 feature will apply to both analog ports.

DTMF Signaling

The DTMF based Caller ID data is transmitted prior to ringing. The sending information includes only the incoming phone number. To select DTMF signaling:

use AT Command: **AT\P5=1<Enter>**

or

use Tone Command: *****125*1#**

FSK Signaling

The FSK based Caller ID data is transmitted during ringing. The FSK encoded message may include phone number, date and time.

Usually the Caller ID device contains a real-time clock, only phone number data is sent toward the Caller ID device. In such case, you only have to adjust Caller ID device's clock at installation. To select FSK signaling:

use AT Command: **AT\P5=0<Enter>**
OR
use Tone Command: *****125*0#**

Some Caller ID devices request the complete information (i.e. Phone Number + Date + Time) from analog port. Otherwise the encoded data is treated as invalid message. While most ISDN switch systems deliver only the phone number. TA has to generate "Date and Time" data by itself. To send extra "Date and Time" FSK message, you need:

use AT Command: **AT\P4=1<Enter>** to send timing data
use AT Command: **AT\P4=0<Enter>** to disable
OR
use Tone Command: *****124*1#** to send timing data
use Tone Command: *****124*0#** to disable

You also need to input the correct date and time into TA for this kind of Caller ID device to work.

To setup date:

use AT Command: **AT\$T0=Month-Day-Year<Enter>**
as **AT\$T0=12-06-00** for Dec 06, 2000
OR
use Tone Command: *****030*Month*Day*Year#**
as *****030*12*06*00** for Dec 06, 2000

To setup time:

use AT Command: **AT\$T1=Hour-Min-Sec<Enter>**
as **AT\$T1=18-20-10** for 06:20:10 pm
OR
use Tone Command: *****031*Hour*Min*Sec#**
as *****031*18*20*10** for 06:20:10 pm

Note: *The programmed Date and Time information inside TA will reset while TA is powered off.*

Type 2: Off-Hook Caller ID Transmission

If your Caller ID device supports Type 2 service, that is "Call Waiting Caller ID", you can enable this feature in your TA. The Caller ID device will display the "Call Waiting" phone number while you are using the phone (Off-Hook). The Type 2 Caller ID is based on FSK signaling. You need to configure this feature for each individual analog port.

use AT Command: **AT!1A0=2<Enter>** to enable on analog port 1
use AT Command: **AT!2A0=2<Enter>** to enable on analog port 2
use AT Command: **AT!1A0=0<Enter>** to disable on analog port 1
use AT Command: **AT!2A0=0<Enter>** to disable on analog port 2
OR
use Tone Command: *****210*2#** to enable on current port
use Tone Command: *****210*0#** to disable on current port

FIRMWARE UPGRADE

This chapter describes the procedures to update firmware.

Your TA lets you conveniently update firmware to obtain new features and enhanced functions. You must use a terminal program that supports the X-modem protocol, such as Hyper Terminal of Windows. Before starting the upgrade, you must download the new firmware from WWW site. Please follow the instructions on the WWW site to get the correct firmware for your device. And follow the steps:

1. Start the terminal program and type:
AT\$D99<Enter>
The device responds:
“Remote Firmware Upgrade Start...”
2. Use the X-modem protocol to upload the new firmware file to your TA. When the installation is completed, the device will restart automatically.

In the unlikely event that your device fails to work after upgrading the firmware and all LEDs (except PWR) flash, please follow step 2 above to upgrade the firmware again.

TROUBLESHOOTING

This chapter provides possible solutions to problems regarding the installation and operation of the TA.

1. I can't install the USB driver on my Win9X platform.
 - ◆ Ensure that you are using the right Win9X driver directory.
 - ◆ In rare case you need to delete the corrupted installation registration key in Windows and install the driver again. Please execute "**regedit**" command (type "regedit" in "**Start/Run**" window of WIN9x, then press "Enter"). Delete the key "**VID_0B55&PID_0001**" and key "**SET0020**"(if this key exists) in "**HKEY_LOCAL_MACHINE/Enum/USB**" directory. Reboot your PC to install the USB driver again.

2. My Caller ID device always shows nothing/error when there is an incoming voice call.
 - ◆ Setup TA to send extra "Date and Time" FSK message for your FSK Caller ID.
 - ◆ Setup TA to send **DTMF** signaling Caller ID message if your device supports DTMF Caller ID.

3. My TA data port stays on 128K(two B channels) when there is an incoming voice call, it should release one B channel for the voice call.
 - ◆ You need to subscribe the **call waiting service** for the Call Bumping feature (Bandwidth release for incoming voice call) to work.

A**TONE AND RING PATTERNS**

Type	Pattern	Description
DT	Depend on your ISDN provider	Dial Tone. It comes from ISDN switch.
LDT	Listing On	Local Dial Tone. It is for en-bloc sending.
BT	0.5 Sec On, 0.5 Sec Off, repeat	Busy Tone.
CWT	0.125 Sec On, 0.125 Sec Off, 0.125 Sec On, 0.625 Sec Off, repeat	Call Waiting Tone.
CFGT	0.125 Sec On, 0.125 Sec Off, repeat	Configuration Tone.
CFMT	1.5 Sec On, 0.5 Sec Off, repeat	Configuration Confirm Tone.
SCT	0.125 Sec On, 0.125 Sec Off, repeat	Sub Command Tone.

Type	Pattern	Description
NRP	1 Sec On, 2 Sec Off, repeat	Normal Ring Pattern.
RR	0.5 Sec On, 0.5 Sec Off, repeat	Remind Ring.

AT COMMAND LIST

AT Commands for Data Port

Command	Description
A	Answer an incoming call
C0=n	Select call type n=1: HDLC transparent n=4: V.120 n=6: X.25 on D channel n=8: PPP or MLP (default)
C1=n	Maximum throughput (1 or 2 B-channel), only available when C0=8 or 9. n=0: 64 kbps (1 B-channel) (default) n=1: 128 kbps (2 B-channel)
D<phone number> [/<sub-address>] [:<user data>]	Dial an outgoing call <phone number> : up to 32 digits of '0'~'9', '*', '#'. '-', ' ', '(', ')', '[', ']' will be ignored <sub-address> : up to 20 digits of '0'~'9', 'a'~'z', 'A'~'Z' <user data> : up to 128 characters for non X.25 call up to 12 characters for X.25 call Note : ATDT, ATDP, and ATDW are the same as ATD
DS=n[:<user data>]	Dial an outgoing call with a pre-stored number <user data> : up to 128 characters for non X.25 call up to 12 characters for X.25 call
DL	Redial last call, include user data
E	Enable/Disable command echo E0: Disable echo function E1: Enable echo function (default)
H	Hang up a call
I	Display product information I2: Display model name I3: Display firmware version I4: Display hardware version
O	Enter data mode from escape mode
Q	Enable/Disable result code Q0: Enable result code (default) Q1: Disable result code
S0=n	Enable/Disable auto answer n=0: Disable auto answer (default) n=1~255: Enable auto answer, answer call after n times of ring
S7=n	Wait for connect time, the unit is second n=1~255, default value is 60
S25=n	DTR transition time, the unit is 0.05 seconds. If the transition period of DTR is less than S25, the system will ignore this transition. n=1~255, default value is 2
S50=n	Forwarding character in data mode. n=0: no forwarding character (default) n=2: select CR as forwarding character
S51=n	Idle timer in data mode, the unit is 0.01 second. n=0: Disable idle timer n=1~255: Enable idle timer, default value is 2
V	Select result code format V0: Digit format V1: Word format (default)
W	Display extended information of "RING" result code W0: no extended information (default) W1: Display phone number of calling site W2: Display user data W3: Display phone number of calling site and user data

X	Enable/Disable extended result code X0: Basic result code (default) X1: Extended result code
Z	Reload user defined profile
&C	DCD signal control &C0: Follow DTR signal &C1: ON only if in communication (default)
&D	DTR signal control &D0: Ignore DTR status &D1: If DTR status is from OFF to ON, make a outgoing call with 1 st pre-stored phone number. Terminate current connection if DTR is from ON to OFF and a connection exist. &D2: If DTR status is from ON to OFF, to terminate current connection if a connection exist (default)
&F	Restore the factory setting
&K	Select flow control mode &K0: Disable flow control &K3: Enable CTS/RTS flow control (default) &K4: Enable XON/XOFF flow control
&S	DSR signal control &S0: Follow DTR signal (default) &S1: Follow DCD signal
&V	Display all parameters setting
&W	Store current parameters setting, include &-leading and non-leading parameters, as user defined profile
%D0=n	Select DTE baud rate when system is powered on n=0: 300 bps n=1: 600 bps n=2: 1200 bps n=3: 2400 bps n=5: 4800 bps n=8: 9600 bps n=11: 19200 bps n=13: 38400 bps n=16: 57600 bps n=17: 115200 bps (default) n=21: 230400 bps
%D1=n	Select DTE attribute when system is powered on n=0: 8 data bits, non parity (default) n=1: 7 data bits, even parity n=2: 7 data bits, odd parity
%Id=<phone number> [/<sub-address>]	Phone number list of incoming call screen for data port, 'd' is 0~4. <phone number> : up to 32 digits of '0'~'9', '*', '#'. '-', ' ', '(', ')', '[', ']' will be ignored <sub-address> : up to 20 digits of '0'~'9', 'a'~'z', 'A'~'Z'
%M1=n	Enable/Disable CHAP n=0: Disable CHAP (default) n=1: Enable CHAP
%M2=n	Enable/Disable "Dynamic Bandwidth Allocation for Voice Call". n=0: Disable n=1: Enable (default)
%M3=n	Set threshold of data loading to add one channel, the unit is kbps. n=0~64: default value is 0
%M4=n	Set threshold of data loading to drop one channel, the unit is kbps. n=0~64: default value is 0
%M5=n	Persist time for monitoring threshold to add or drop one channel, the unit is 5 seconds. n=1~255: default value is 1
%Od=<prefix digits >	Prefix digits list of outgoing call screen for data port, 'd' is 0~2.
%P0=n	Select incoming call screen mode. n=0: Accept all incoming calls (default) n=1: Reject all incoming calls n=2: Only accept the calls from the list (set by %I) n=3: Only reject the calls from the list (set by %I)
%P1=n	Select outgoing call screen mode.

	n=0: Not any restriction (default) n=1: Prohibit all outgoing calls n=2: Only accept the calls with the prefix in the list (set by %O) n=3: Only reject the calls with the prefix in the list (set by %O)
%P2=n	Select CLIP (Calling Line Identification Presentation) or CLIR (Calling Line Identification Restriction) n=0: Select CLIR, ask ISDN switch to not pass my phone number to destination site. n=1: Select CLIP, ask ISDN switch to pass my phone number to destination site. n=2: Depends on what you subscribed for with telephone company (default)
%S0=<phone number> [/<sub-address>]	Assign phone number for data port. <phone number> : up to 32 digits of '0'~'9', '*', '#'. '-', ' ', '(', ')', '[', ']' will be ignored <sub-address> : up to 20 digits of '0'~'9', 'a'~'z', 'A'~'Z'
-B0=n	Select window size for X.25 n=1~7 default value is 2
-B1=n	Select packet size for X.25 n=7 128 bytes (default) n=8 256 bytes
-B2=n	Accept/Reject X.25 reverse charge call n=0 reject (default) n=1 accept
-B3=n	Assign fixed TEI for X.25 PVC call n=0~63 default value is 0
-B4=n	Select X.25 call type, VC or PVC n=0 VC (default) n=1~255 PVC (LCN is n)
-B5=n	Select X.25 LCGN (Logic Channel Group Number) n=0~15 default value is 0
-B6=n	Assign X.25 LCN (Logic Channel Number) range n=1~255, the default value is 7
-B7=n	Enable/Disable X.25 D bit n=0 disable n=1 enable
-X=<phone number>	Assign phone number for X.25
-Zd=<phone number> [/<sub-address>]	Set pre-stored phone number for data port, 'd' is 0~4. <phone number> : up to 32 digits of '0'~'9', '*', '#'. '-', ' ', '(', ')', '[', ']' will be ignored <sub-address> : up to 20 digits of '0'~'9', 'a'~'z', 'A'~'Z'

AT Commands for Analog Ports

Command	Description
\P0=n	Select CODEC type. You don't need to change this setting unless using the TA in another country. n=0: A-law (default) n=1: μ -law
\P1=n	Select dialing method for analog port. n=0: Overlap sending, it is the same as a traditional telephone system (default). n=1: En-bloc sending. You must press '#' after all the phone number digits are input.
\P2=n	Set priority for analog ports. For an incoming call, if both ports pass MSN checking, the TA handles the call depending on the priority setting. If both ports are the same priority, both ports will ring. Otherwise, only the port with the high priority rings. n=0: Both ports are same priority (default) n=1: TEL1 is high priority n=2: TEL2 is high priority
\P4=n	n=0: Disable timing data for FSK caller ID (default) n=1: Send timing data for FSK caller ID
\P5=n	n=0: Select FSK signaling for caller ID n=1: Select DTMF signaling for caller ID (default)

AT Command Result Codes

Digit Format	Word Format	Basic (X0)	Extended (X1)
0	OK	✓	✓
1	CONNECT	✓	
2	RING	✓	✓
3	NO CARRIER	✓	✓
4	ERROR	✓	✓
10	CONNECT 0.3K		✓
11	CONNECT 0.6K		✓
12	CONNECT 1.2K		✓
13	CONNECT 2.4K		✓
15	CONNECT 4.8K		✓
18	CONNECT 9.6K		✓
21	CONNECT 19.2K		✓
23	CONNECT 38.4K		✓
26	CONNECT 57.6K		✓
27	CONNECT 115.2K		✓
31	CONNECT 230.4K		✓
33	CONNECT 64K		✓
34	CONNECT 128K		✓



TONE COMMAND LIST

Tone Command	AT Command	Description
991*99#	\$F99	Set all parameters to default value
011*n#	\$P1	Select active device in remote power mode
030*n#	\$T0	Set date
031*n#	\$T1	Set time
120*n#	\P0	Select CODEC type
121*n#	\P1	Select dialing method for analog port
122*n#	\P2	Set priority for analog ports
124*n#	\P4	Enable/Disable to send timing data for caller ID
125*n#	\P5	Select FSK/DTMF signaling for caller ID
13d*<phone number> [*<sub-address>]#	\Zd	Set pre-stored phone number for analog ports
210*n#	!pA0	Device type on analog port.
211*n#	!pA1	Enable/Disable Call waiting
220*n#	!pP0	Select incoming call screening mode for analog port
221*n#	!pP1	Select outgoing call screening mode for analog port.
222*n#	!pP2	Select CLIP (Calling Line Identification Presentation) or CLIR (Calling Line Identification Restriction) for analog port
310*<phone number> [*<sub-address>]#	!pS	Assign phone number for analog port.
32d*<phone number> [*<sub-address>]#	!pId	Phone number list of incoming call screening for analog port
35d*<prefix digits >#	!pOd	Prefix digits list of outgoing call screening for analog port

Note: For more detailed description, see Appendix B



TERMINATION RESISTOR

Termination resistor requirements vary depending on the number and position of S/T interface devices connected to this TA.

Single S/T device

- ◆ Set the TA and S/T device to 100 ohm.

Multiple S/T devices

- ◆ Set to 100 ohm if the TA is on the endpoint. You also need to set the S/T device on the other endpoint to 100 ohm.
- ◆ Set to none if it is in the middle position. You must set the device on the endpoint to 100 ohm.



SPECIFICATIONS

NETWORK CONNECTION

ISDN U Interface
Complies with ETSI ETR 080
Line Code: 2B1Q, Echo Cancellation
Switch Compatibility: EURO ISDN DSS1
Connector: RJ11

S/T INTERFACE DROP

Complies with I.430
Connector: RJ45*2
Supports Point-to-Point, Short Passive Bus, and Extended Passive Bus

DATA INTERFACE

1 RS-232 Port with DB9 connector, Data Rate up to 230.4 Kbps
1 USB Port with Type B connector, Compatible with USB Spec 1.1

ANALOG PORTS

2 Ports with RJ11 connector

DISPLAY (LEDs)

8 LEDs for Power, Line, and Port (Telephone and Data) status

POWER

AC Input: 100V~240V AC
Power Consumption: < 8 Watts at full operation,
< 1.8 Watts at remote power operation

ENVIRONMENTAL AND SAFETY

Operation Temperature: 0 ~ 40 degrees Celsius
Relative Humidity: 10 ~ 90% non-condensing

PHYSICAL

Dimensions: 178mm (W) x 136mm (D) x 35mm (H)
Weight: < 700 g